



Primelite Manufacturing Corp

407 S Main St, Freeport, NY 11520

Phone: 516-868-4411 | Fax: 516-868-4609
 sales@primelite-mfg.com | www.primelite-mfg.com

PART # #5796 LED 100	LAMP Built-In LED	VOLTAGE 120 - 277 V	COLOR Powder Coated Paint
JOB NAME			TYPE Linear Sign Light

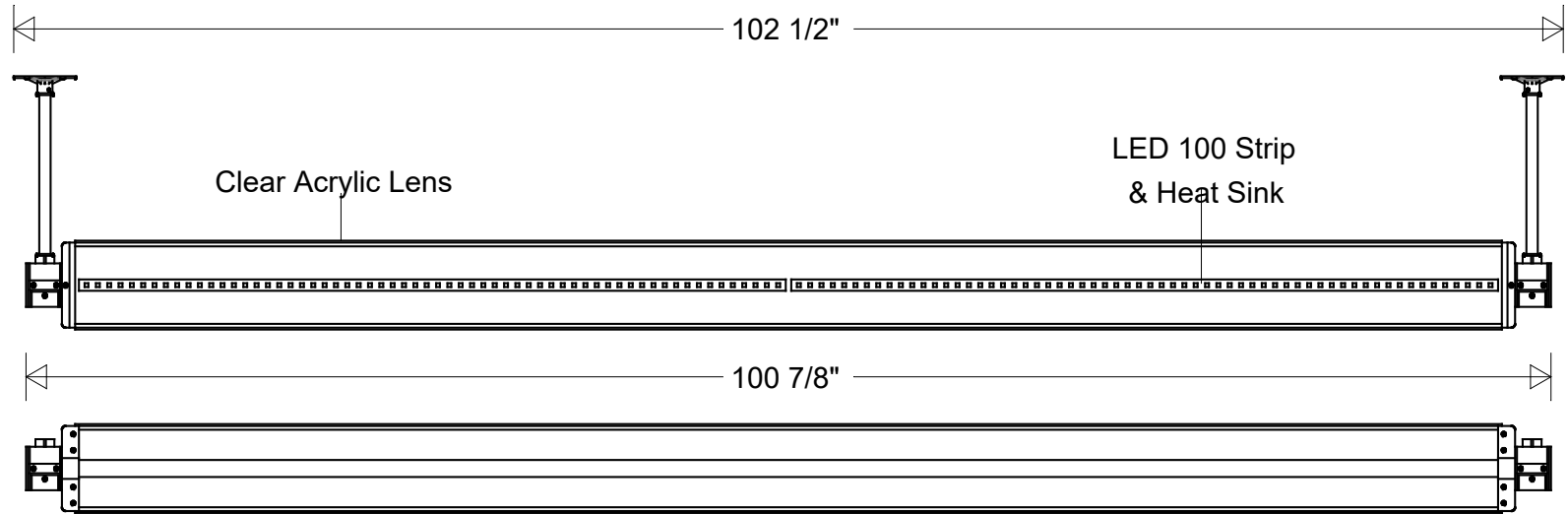
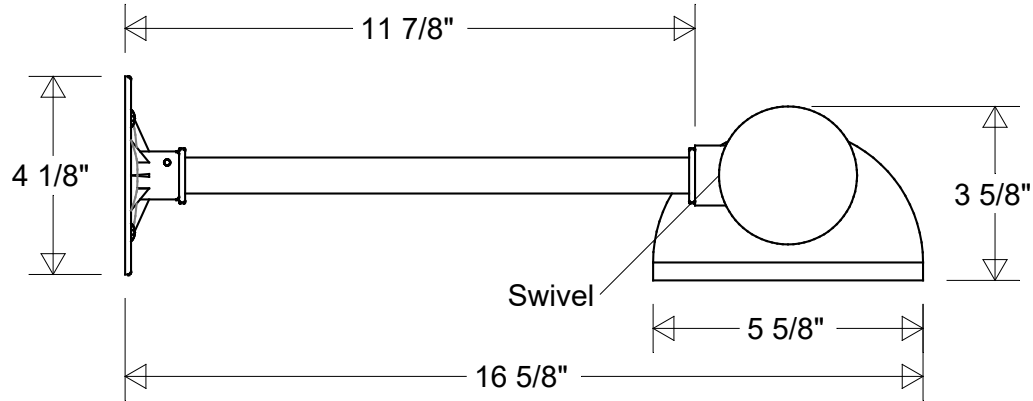

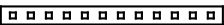
Lamp: LED 100 (LED 50 Strip X 2) 35K = 14000 Lumens 5K = 14000 Lumens 	Initials	Date	#5796 LED 100			
	Drawn	CB				02/2023
	Checked			102 1/2" L 16 5/8" Ext 3 5/8" H 98 3/8" Center to Center		
	ENG Appr.					
Construction: Aluminum Acrylic	MFR Appr.		Size A	Drawing No. 0001	Rev A	
Unless Otherwise Specified: Dimensions in Inches	Weight:		Scale	CAD File	Sheet 1 of 1	

Revisions				
Zone	Rev	Description	Date	Appr