





Primelite Manufacturing Corp

407 S Main St, Freeport, NY 11520

Phone: 516-868-4411 | Fax: 516-868-4609
 sales@primelite-mfg.com | www.primelite-mfg.com

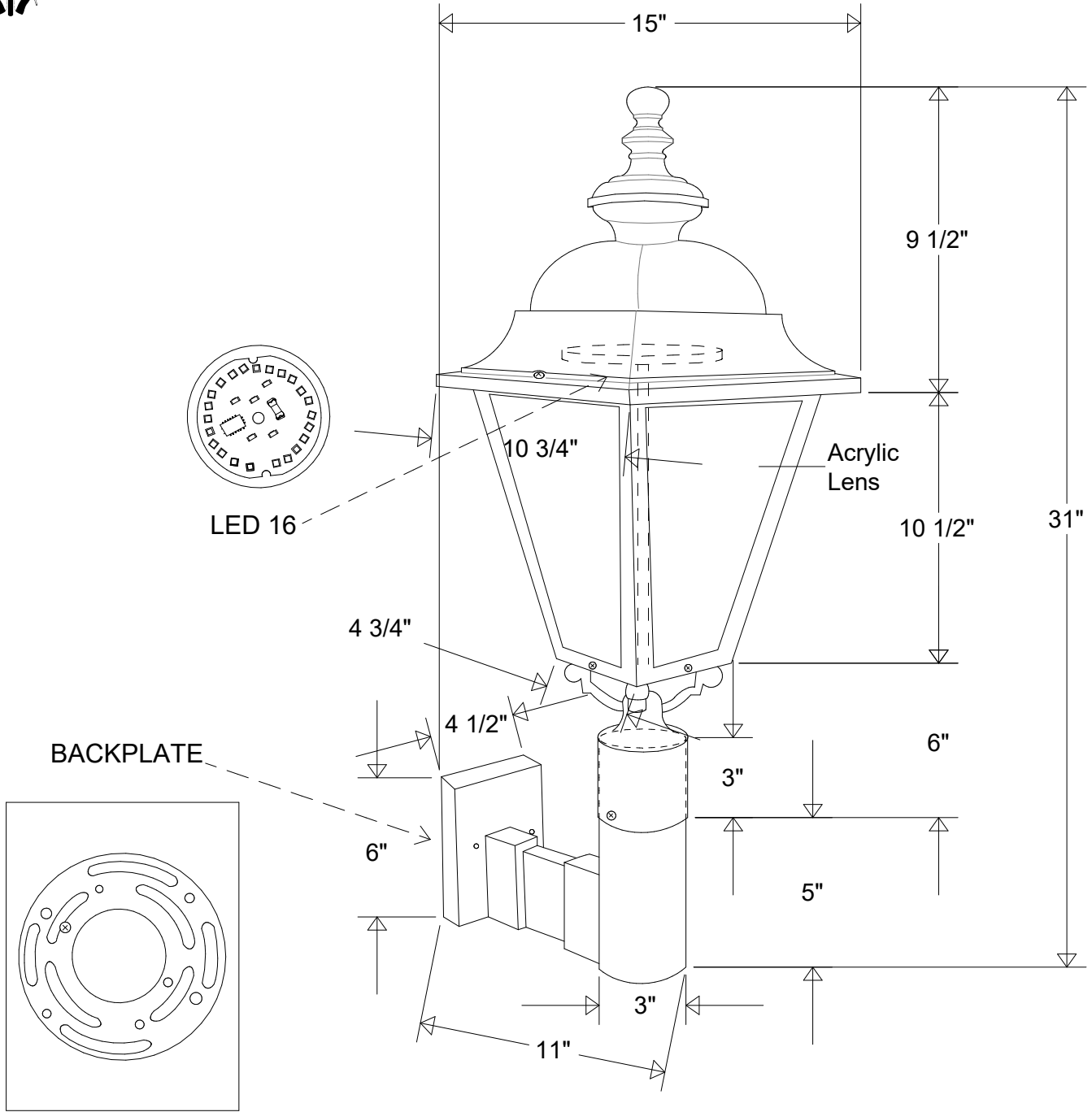
| | | | |
|-----------------|----------------------------|------------------|---------------------------------|
| PART # #3261 | LAMP Incandescent LED | VOLTAGE 120 V | COLOR Powder Coated Paint |
| JOB NAME | | | TYPE Wall Sconce |



| Lamp: Incandescent LED  LED 16 | Name | | Date | | Wall Sconce #3261 LED 16 15" Ext 31" H Acrylic Lens Smoke White Clear Frosted | | | | | | | | | | | | | | | | | | | | | | | | | | | | | |
|---|---------|-----|-------------|----------|---|----------|---------------|--|--|------|-----|-------------|------|----------|--|--|--|--|--|--|--|--|--|--|--|--|--|--|--|--|--|--|--|--|
| | Drawn | CB | 11/19 | | | | | | | | | | | | | | | | | | | | | | | | | | | | | | | |
| | Checked | | | | Revisions <table border="1"> <thead> <tr> <th>Zone</th> <th>Rev</th> <th>Description</th> <th>Date</th> <th>Approved</th> </tr> </thead> <tbody> <tr><td> </td><td> </td><td> </td><td> </td><td> </td></tr> <tr><td> </td><td> </td><td> </td><td> </td><td> </td></tr> <tr><td> </td><td> </td><td> </td><td> </td><td> </td></tr> <tr><td> </td><td> </td><td> </td><td> </td><td> </td></tr> </tbody> </table> | | | | | Zone | Rev | Description | Date | Approved | | | | | | | | | | | | | | | | | | | | |
| | Zone | Rev | Description | Date | Approved | | | | | | | | | | | | | | | | | | | | | | | | | | | | | |
| | | | | | | | | | | | | | | | | | | | | | | | | | | | | | | | | | | |
| | | | | | | | | | | | | | | | | | | | | | | | | | | | | | | | | | | |
| | | | | | | | | | | | | | | | | | | | | | | | | | | | | | | | | | | |
| | | | | | | | | | | | | | | | | | | | | | | | | | | | | | | | | | | |
| ENG Appr. | | | | Size | Drawing No. | Rev | | | | | | | | | | | | | | | | | | | | | | | | | | | | |
| MFR Appr. | | | | A | 0001 | A | | | | | | | | | | | | | | | | | | | | | | | | | | | | |
| Construction: Aluminum Acrylic | QA | | | Scale | CAD File | Sheet | 1 of 1 | | | | | | | | | | | | | | | | | | | | | | | | | | | |
| Unless Otherwise Specified: Dimensions in Inches | Weight | | | | | | | | | | | | | | | | | | | | | | | | | | | | | | | | | |