

Revisions			Date	Approved
Zone	Rev	Description		

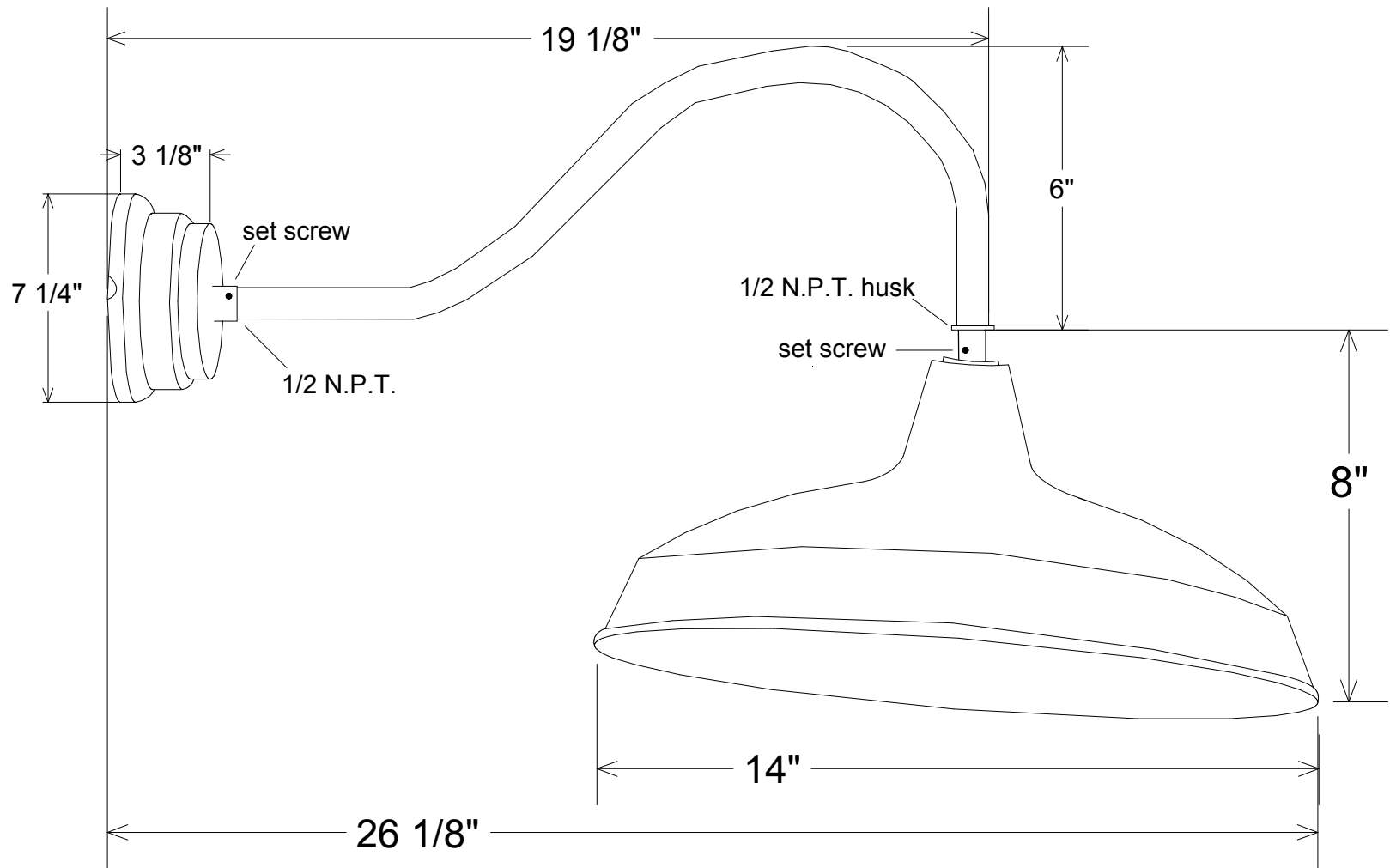

<b>Unless Otherwise Specified:</b> Dimensions in Inches Tolerances: Fractional ± Angular: Mach ± Bend ± Two Place Decimal ± Three Place Decimal ±	<b>Drawn</b> T.A.R.	<b>Date</b> 11/25/09	<b>Primelite Mfg. Corp.</b>  <b>23/14-859 PLT42</b>  <b>14" RLM Angle Arm Short with Ballast Pot</b>	
	<b>Checked</b> ENG Appr.			
	<b>MFR Appr.</b> MFR Appr.			
	<b>QA</b> QA			
	<b>Comments</b> CAD Generated Drawing Do Not Manually Update			
<b>Construction: All Aluminum</b>	<b>Size</b> <b>A</b>		<b>Drawing No.</b> <b>0001</b>	<b>Rev</b> <b>A</b>
<b>Pipe Size: 1/2"</b>	<b>Scale</b> <b>1:4</b>		<b>CAD File</b>	<b>Sheet</b> <b>1 of 1</b>
<b>Lamp: PLT 42</b>				