



# Primelite Manufacturing Corp

407 S Main St, Freeport, NY 11520

Phone: 516-868-4411 | Fax: 516-868-4609  
 sales@primelite-mfg.com | www.primelite-mfg.com

PART # #20/850 ESW LED 12	LAMP Built-In LED	VOLTAGE 120 V	COLOR Powder Coated Paint
JOB NAME			TYPE Gooseneck

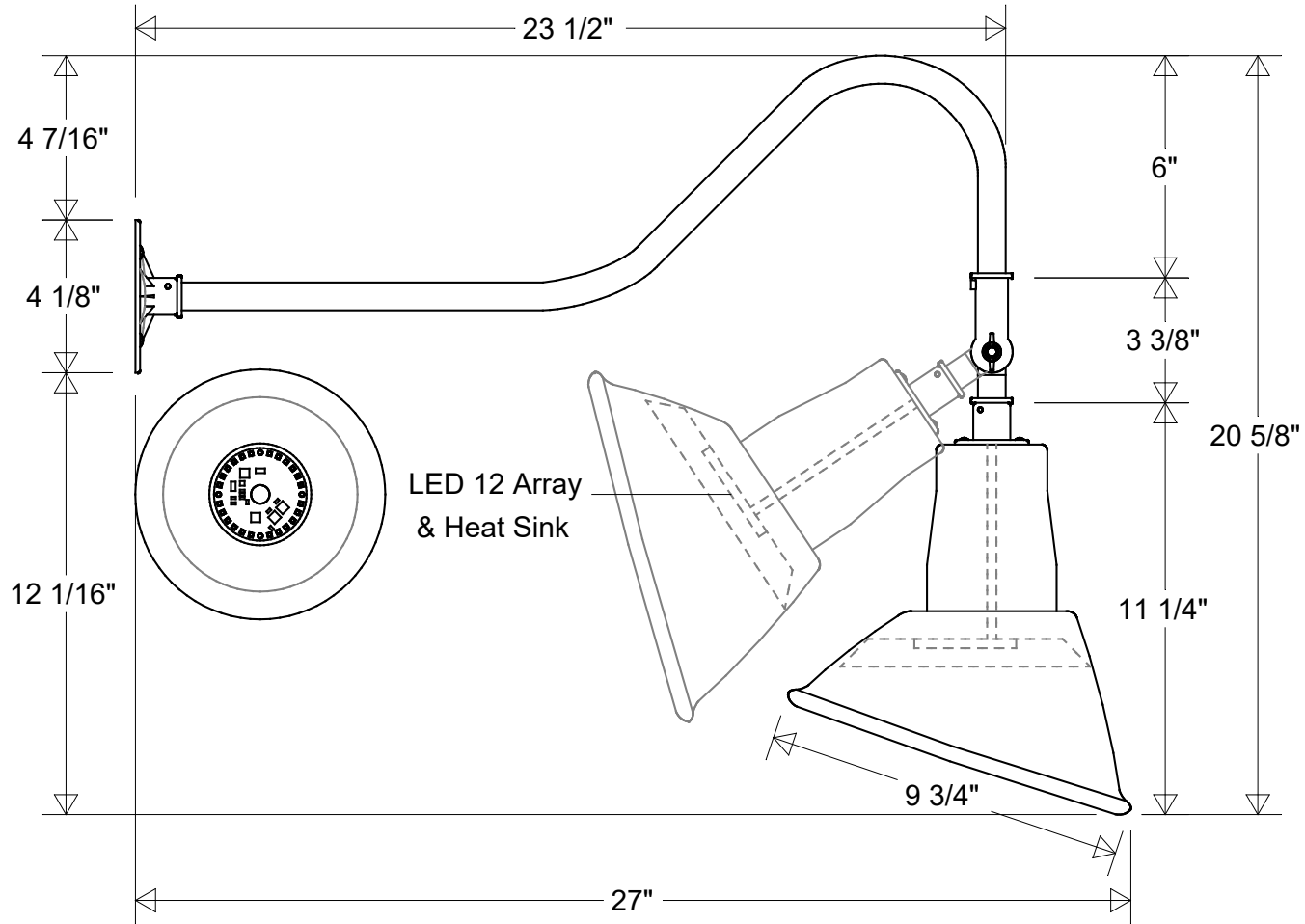

Lamp: LED 12 Array  
 60 W Inc Equivalent  
 3K = 910 Lumens  
 4K = 1000 Lumens



	Initials	Date
Drawn	CB	06/2022
Checked		
ENG Appr.		
MFR Appr.		
QA		

## Gooseneck #20/850 ESW LED 12

9 3/4" Dia | 27" Ext | 20 5/8" H

Adjustable Angle Swivel

Size	Drawing No.	Rev
<b>A</b>	<b>0001</b>	<b>A</b>

Revisions				
Zone	Rev	Description	Date	Appr

Unless Otherwise Specified:  
 Dimensions in Inches

Weight:

Scale	CAD File	Sheet
		<b>1 of 1</b>