



Primelite Manufacturing Corp.

407 S Main St, Freeport, NY 11520
 Phone: (516) 868-4411 | Fax: (516) 868-4609
 sales@primelite-mfg.com | www.primelite-mfg.com

PROUDLY MADE IN THE USA SINCE 1962!
"SPECIALTIES ARE OUR SPECIALTY!"

Job Info

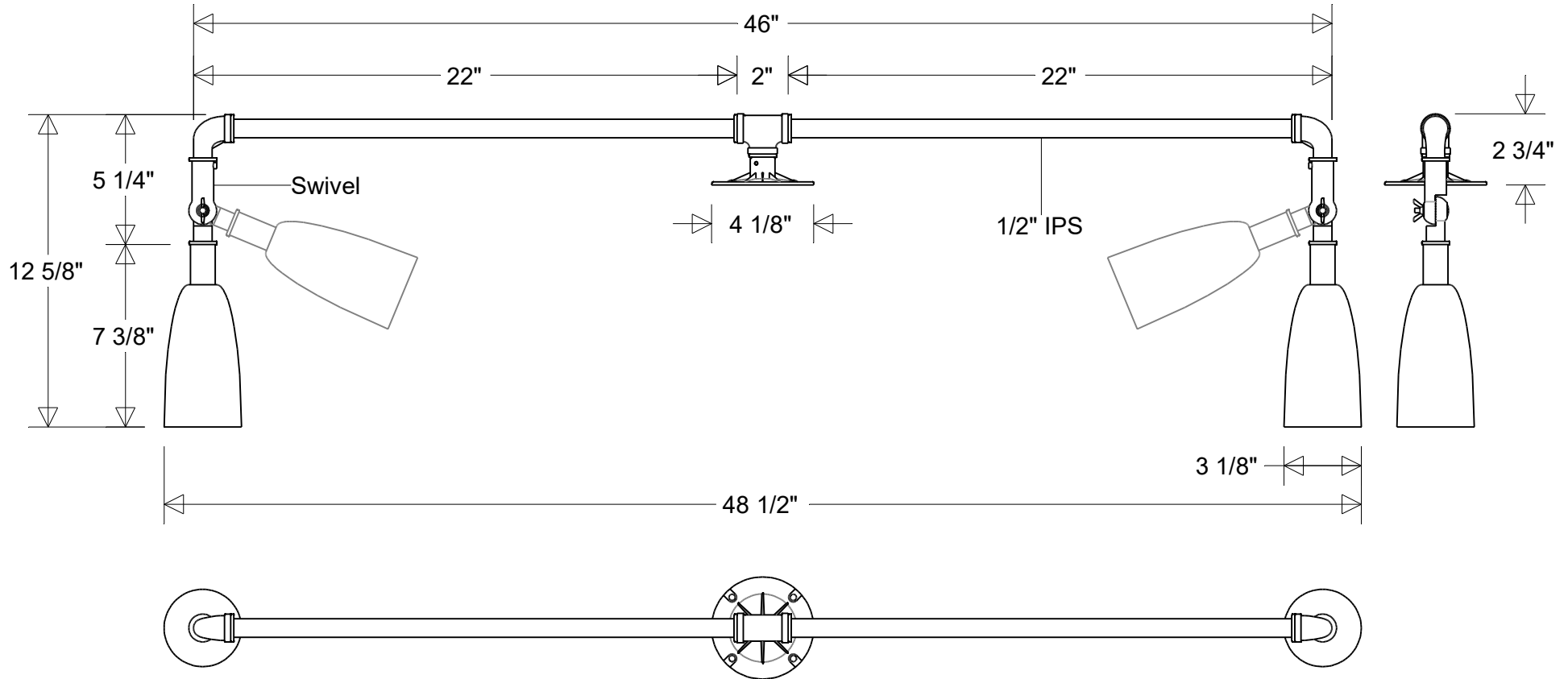

#18/855-ESW-P2 Series

3 1/8" Dia | 48 1/2" Ext | 12 5/8" H
 Shade: #18A Series | Arm: #855-ESW-P2

Lamp Options:

E26 Socket
 LED12

Finish:

29 Oven Baked
 Powder Coated Paints

Material:

Aluminum

Drawn:

CB
 05/2026

Scale:

1 / 6.25

Approvals

Note:

All dimensions are nominal.
 Actual dimensions may vary.



Primelite Manufacturing Corp.

407 S Main St, Freeport, NY 11520
 Phone: (516) 868-4411 | Fax: (516) 868-4609
 sales@primelite-mfg.com | www.primelite-mfg.com

PROUDLY MADE IN THE USA SINCE 1962!
"SPECIALTIES ARE OUR SPECIALTY!"

Job Info

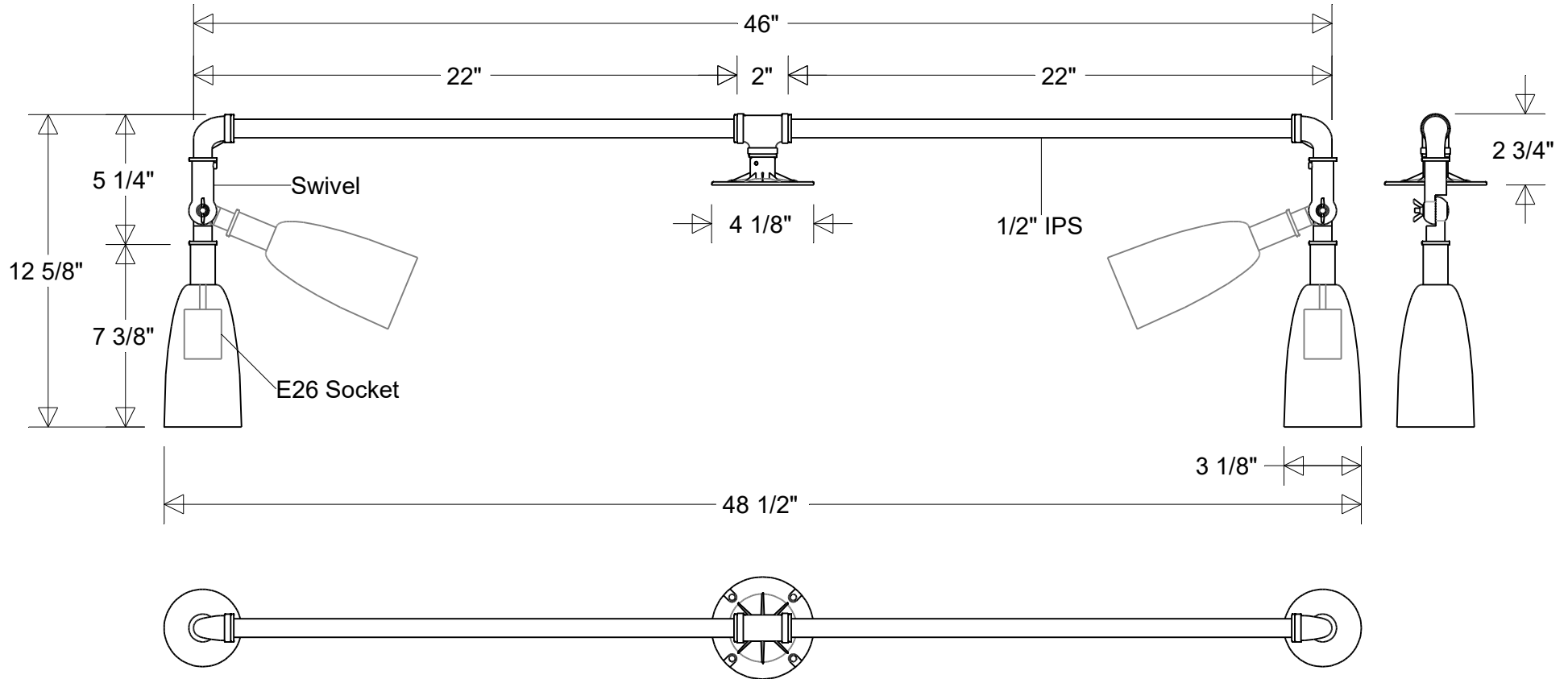

#18/855-ESW-P2

3 1/8" Dia | 48 1/2" Ext | 12 5/8" H
 Shade: #18A | Arm: #855-ESW-P2

Lamp: E26 Socket Max Wattage: 60 W each Number of Sockets: 2 120 V	Finish: 29 Oven Baked Powder Coated Paints Material: Aluminum	Drawn: CB 05/2026 Note: All dimensions are nominal. Actual dimensions may vary.	Scale: 1 / 6.25	Approvals	



Primelite Manufacturing Corp.

407 S Main St, Freeport, NY 11520
 Phone: (516) 868-4411 | Fax: (516) 868-4609
 sales@primelite-mfg.com | www.primelite-mfg.com

PROUDLY MADE IN THE USA SINCE 1962!
"SPECIALTIES ARE OUR SPECIALTY!"

Job Info

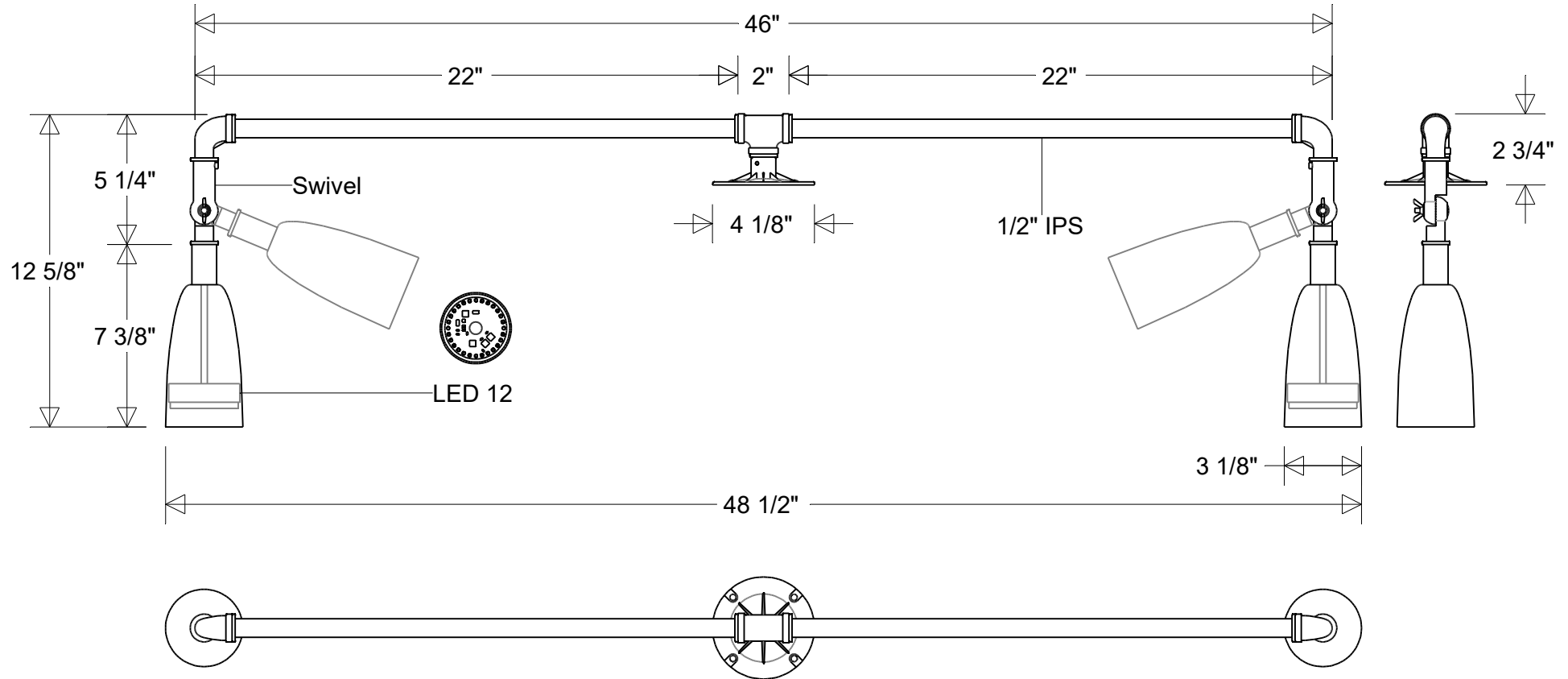

#18/855-ESW-P2 LED 12

3 1/8" Dia | 48 1/2" Ext | 12 5/8" H
 Shade: #18A LED 12 | Arm: #855-ESW-P2

Lamp: 12 W LED
 CCT: 3K or 4K
 75W Inc Equivalent
 80 CRI
 120V
 Electronic Dimming

Finish:
 29 Oven Baked
 Powder Coated Paints
Material:
 Aluminum

Drawn:
 CB
 05/2026
Scale:
 1 / 6.25

Note:
 All dimensions are nominal.
 Actual dimensions may vary.

Approvals
