



Primelite Manufacturing Corp

407 S Main St, Freeport, NY 11520

Phone: 516-868-4411 | Fax: 516-868-4609
 sales@primelite-mfg.com | www.primelite-mfg.com

PART # #1217 LED 68	LAMP Built-In LED	VOLTAGE 120 V	COLOR Powder Coated Paint
JOB NAME			TYPE Post Light

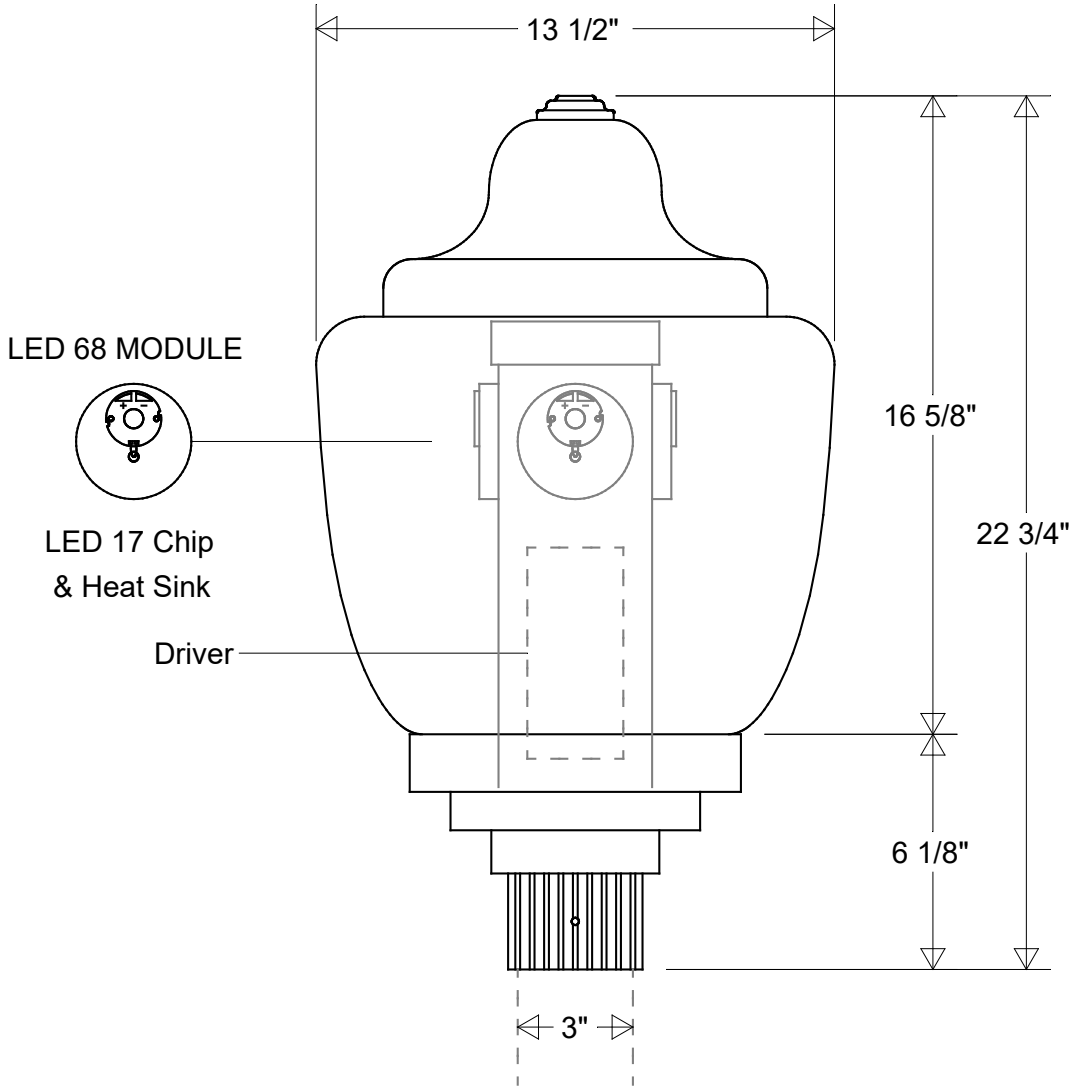

Lamp: LED 68 Module

175 W MH Equivalent
 3K = 7712 Lumens
 4K = 8552 Lumens



	Initials	Date
Drawn	CB	08/2022
Checked		
ENG Appr.		
MFR Appr.		
QA		

Post Light #1217 LED 68

13 1/2" Dia | 22 3/4" H

Fits 3" OD Round Posts & Pier Mounts

Revisions

Zone	Rev	Description	Date	Appr

Construction:
 Aluminum | Polycarbonate

Weight:	
----------------	--

Size	Drawing No.	Rev
A	0001	A

Unless Otherwise Specified:
 Dimensions in Inches

Scale	CAD File	Sheet
		1 of 1