



# Primelite Manufacturing Corp.

407 S Main St, Freeport, NY 11520  
 Phone: (516) 868-4411 | Fax: (516) 868-4609  
 sales@primelite-mfg.com | www.primelite-mfg.com

**PROUDLY MADE IN THE USA SINCE 1962!**  
**"SPECIALTIES ARE OUR SPECIALTY!"**

Job Info

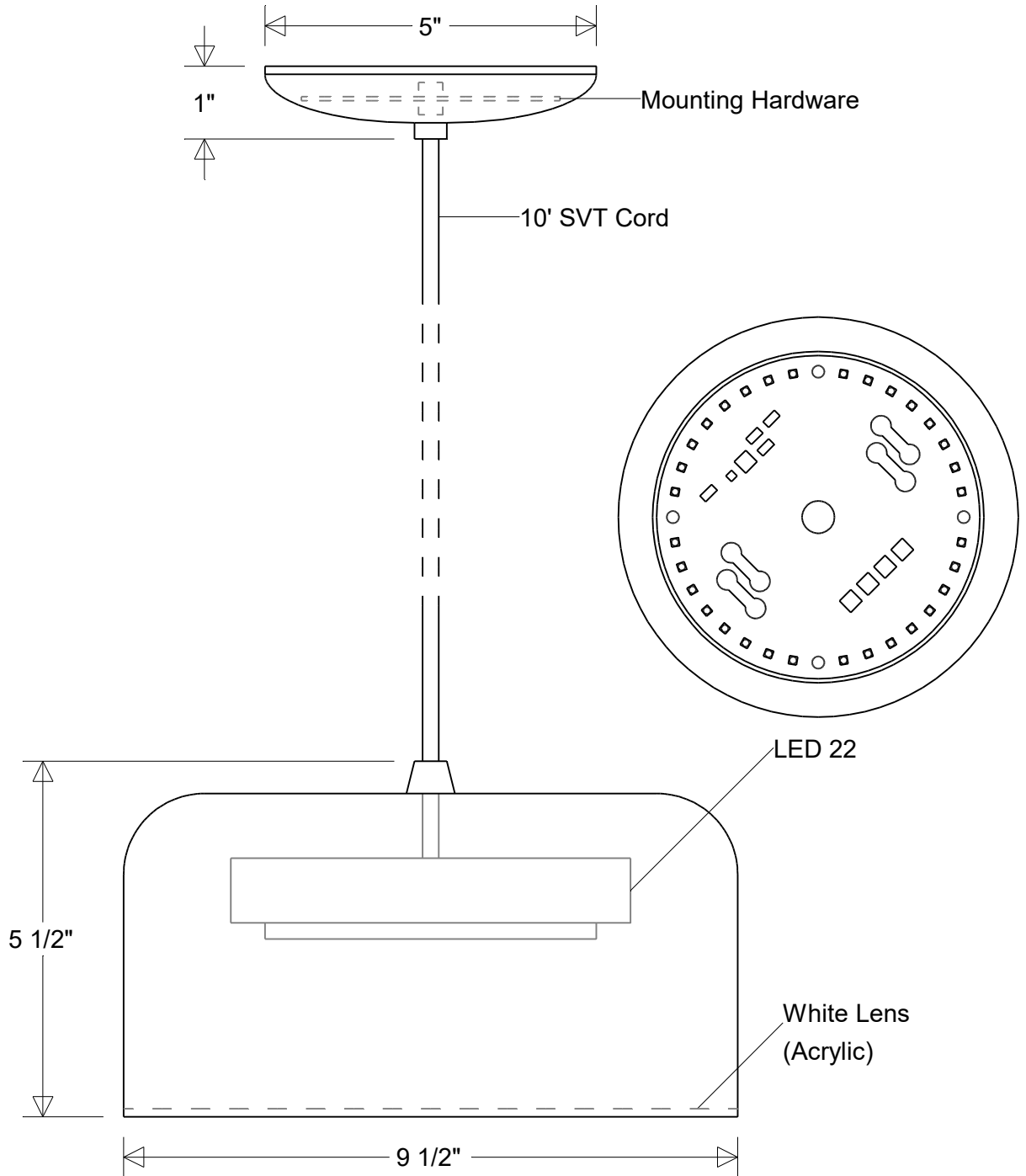

## #11038/10 LED 22

9 1/2" Dia | 5 1/2" H  
 10' SVT Cord: Black / White

**Lamp: 22 W LED**  
 CCT: 3K or 4K  
 125W Inc Equivalent  
 80 CRI  
 120V  
 Electronic Dimming

**Finish:**  
 29 Oven Baked  
 Powder Coated Paints  
**Material:**  
 Aluminum  
 Acrylic Lens

**Drawn:**  
 CB  
 04/2026  
**Note:**  
 All dimensions are nominal.  
 Actual dimensions may vary.

**Scale:**  
 1 / 2.5

Approvals