



# Primelite Manufacturing Corp.

407 S Main St, Freeport, NY 11520  
 Phone: (516) 868-4411 | Fax: (516) 868-4609  
 sales@primelite-mfg.com | www.primelite-mfg.com

**PROUDLY MADE IN THE USA SINCE 1962!**  
**"SPECIALTIES ARE OUR SPECIALTY!"**

Job Info

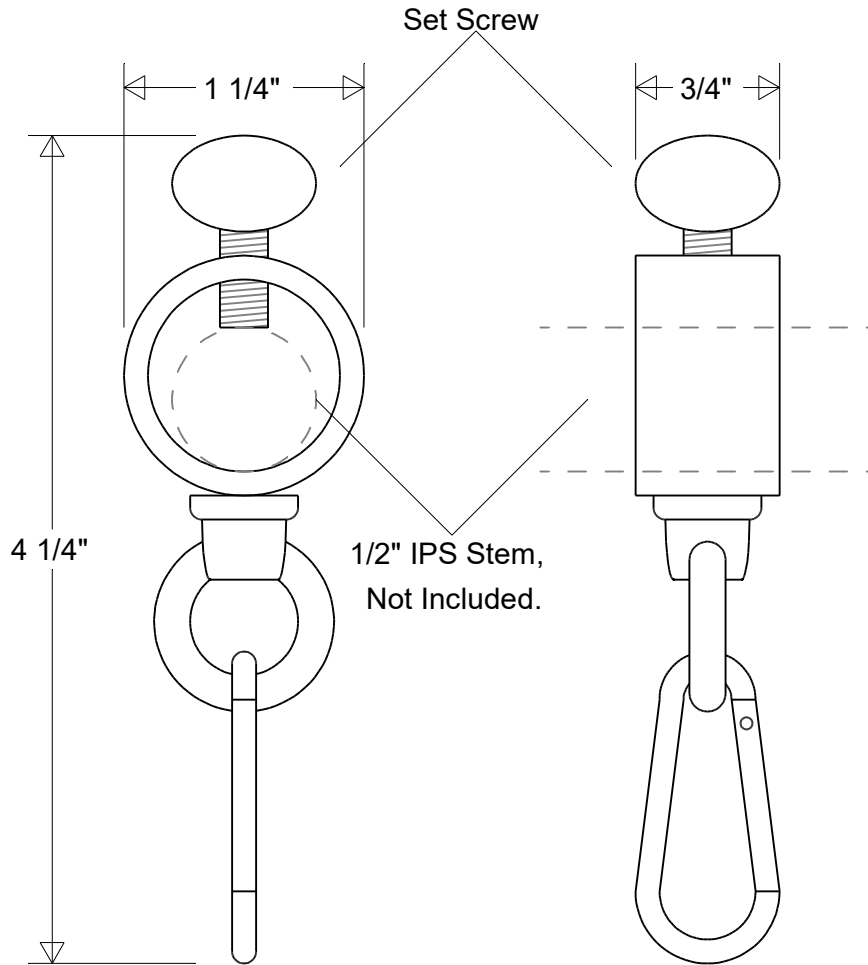

**#102**

1 1/4" Dia | 3/4" W | 4 1/4" H  
 Fits 1/2" IPS Stems & Arms

Lamp: N/A

Finish:  
 29 Oven Baked  
 Powder Coated Paints

Drawn:  
 CB  
 05/2025

Scale:  
 1/1

Approvals

Voltage: N/A

Material:  
 Aluminum

Note:  
 All dimensions are nominal.  
 Actual dimensions may vary.